

UNCONTROLLED DOCUMENT

PART NUMBER		REV.
SSL-LX5093SRSGW		C
REV.	E.C.N. NUMBER AND REVISION COMMENTS	DATE
A	CHG'D POWER DISSIPATION.	11.16.92
B	UPDATED SPECS.	10.11.94
C	E.C.N. #11148	10.25.06

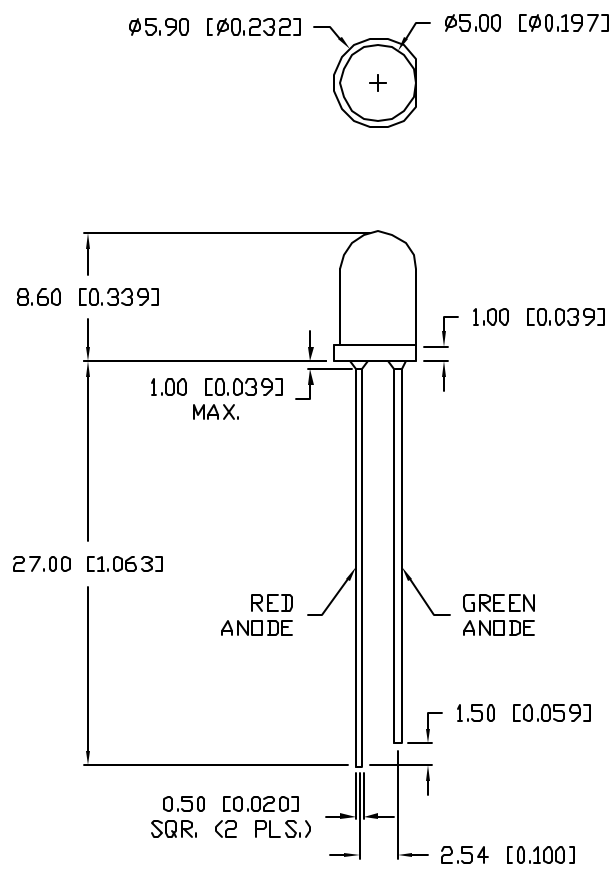

ELECTRO-OPTICAL CHARACTERISTICS  $T_A=25^{\circ}\text{C}$   $I_f=20\text{mA}$

PARAMETER	MIN	TYP	MAX	UNITS	TEST COND
PEAK WAVELENGTH		660 (RED)		nm	
		565 (GREEN)		nm	
FORWARD VOLTAGE (R/G)		1.7/2.2	2.2/2.6	$V_f$	
REVERSE VOLTAGE (R/G)	4.0/5.0			$V_r$	$I_f=100\mu\text{A}$
AXIAL INTENSITY (R/G)		140/25		mcd	$I_f=20\text{mA}$
VIEWING ANGLE		60		2x theta	
EMITTED COLOR:	RED/GREEN				
EPOXY LENS FINISH:	MILKY WHITE DIFFUSED				

LIMITS OF SAFE OPERATION AT 25°C

PARAMETER	COLORS	MAX	UNITS
PEAK FORWARD CURRENT*		150	mA
STEADY CURRENT	(R/G)	30/25	mA
POWER DISSIPATION	(R/G)	100/105	mW
DERATE FROM 25°C		-1.2	mW/°C
OPERATING, STORAGE TEMP.		-40 TO +85	°C
SOLDERING TEMP.		+260	°C
2.0mm FROM BODY			3 SEC. MAX

\*  $t < 10\mu\text{s}$



UNCONTROLLED DOCUMENT

\*UNLESS OTHERWISE SPECIFIED TOLERANCES PER DECIMAL PRECISION ARE: X=±1 (±0.039), XX=±0.5 (±0.020), XXX=±0.25 (±0.010), XXXX=±0.127 (±0.005). LEAD SIZE=±0.05 (±0.002), LEAD LENGTH=±0.75 (±0.030), MIN. <sup>+DECIMAL PRECISION</sup> MAX. = <sup>+0.00</sup> <sub>-0.00</sub> DECIMAL PRECISION

REV.	PART NUMBER
C	SSL-LX5093SRSGW
T-5mm 660nm SUPER RED/565nm SUPER GREEN LED, MILKY WHITE LENS.	

**CONFIDENTIAL INFORMATION**  
 THE INFORMATION CONTAINED IN THIS DOCUMENT IS THE PROPERTY OF LUMEX INC. EXCEPT AS SPECIFICALLY AUTHORIZED IN WRITING BY LUMEX INC., THE HOLDER OF THIS DOCUMENT SHALL KEEP ALL INFORMATION CONTAINED HEREIN CONFIDENTIAL AND SHALL PROTECT SAME IN WHOLE OR IN PART FROM DISCLOSURE AND DISSEMINATION TO ALL THIRD PARTIES.

**RELIABILITY NOTE**  
 OUR MANY YEARS OF EXPERIENCE DATA ACCUMULATION INDICATE THAT SOLDER HEAT IS A MAJOR CAUSE OF EARLY AND FUTURE FAILURE. PLEASE PAY ATTENTION TO YOUR SOLDERING PROCESS.



290 E. HELEN ROAD  
 PALATINE, IL 60067-6976  
 PHONE: +1.847.359.2790  
 US WEB: www.lumex.com  
 TW WEB: www.lumex.com.tw

DRAWN BY:	CHECKED BY:	APPROVED BY:	DATE: 10.25.06
JC			PAGE: 1 OF 1
			SCALE: N/A